



RM-6429

B. E. - II (Sem. IV) (Chem.) Examination

May / June - 2010

Strength of Materials - II

Time : 3 Hours]

[Total Marks : 100

Instructions :

(1)

नीचे दृशावेव निशानीवाणी विगतो उत्तरवडी पर अवश्य लपवी. Fillup strictly the details of signs on your answer book.	Seat No. :
Name of the Examination :	<input type="text"/>
<input type="text" value="B. E. - 2 (Sem. 4) (Chem.)"/>	<input type="text"/>
Name of the Subject :	<input type="text"/>
<input type="text" value="Strength of Materials - 2"/>	<input type="text"/>
Subject Code No. : <input type="text" value="6"/> <input type="text" value="4"/> <input type="text" value="2"/> <input type="text" value="9"/>	<input type="text" value="Student's Signature"/>
Section No. (1, 2,...): <input type="text" value="1&2"/>	

- (2) Answers to the two sections should be written in separate answer books.
- (3) Assume suitable data wherever necessary and specifically mention them.
- (4) Figures to the right indicate full marks.

SECTION - I

- 1 (a) Fill in the blanks : 10
- (i) Maximum principal stress theory is suitable for _____ material.
- (ii) "In any structure, the partial differential coefficient of total strain energy with respect to load at any point gives displacement under the load." This is _____ theorem.
- (iii) Nature of stress at the inner surface of crane-hook is _____ (Tensile, compressive)
- (iv) Castigliano's theorem finds deflection under (point load, uniformly distributed load)
- (v) Ratio of ultimate stress to allowable stress is known as _____.

- (vi) Area under stress-strain diagram upto elastic limit gives _____.
- (vii) Maximum shear stress theory was given by _____.
- (viii) Temperature at any point in an elastic continuum is a function of _____.
- (ix) Ratio of stress developed due to suddenly applied load to gradually applied load is _____.
- (x) Load-deflection curve for the material loaded upto elastic limit gives proof resilience _____.
(True/false)

(b) (i) Write the statement (only) of Bett's law. 4

OR

(i) Derive an expression of strain energy for a circular bar subjected to an axial tensile load _____.

(b) (ii) Find the expression for vertical and horizontal deflection for the structure shown in figure 1.

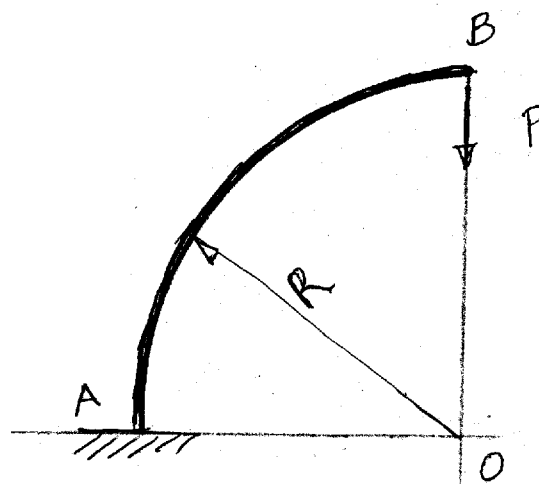
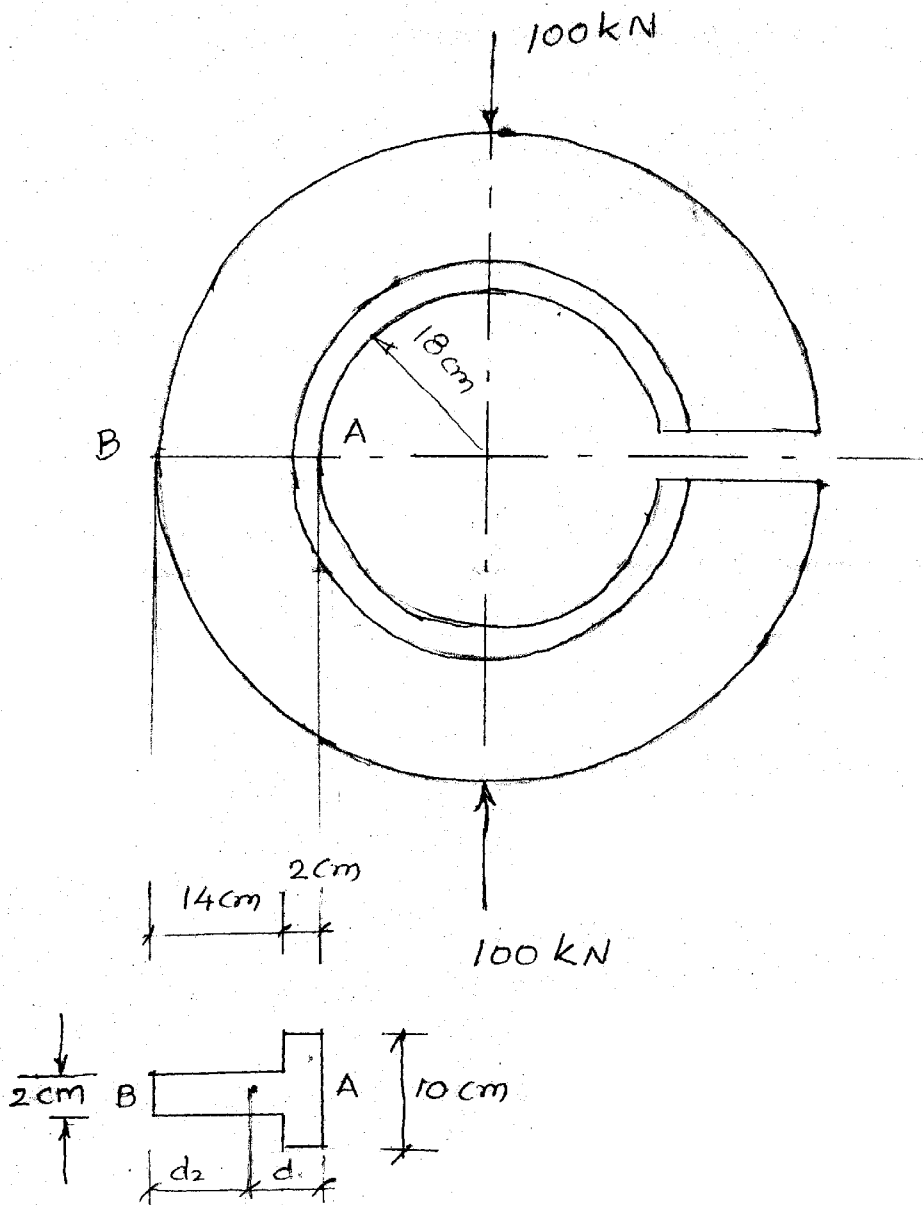

FIG - 1

- 2 (a) Write critical stresses in a crane hook. Justify your answer with suitable sketch. 6

OR

- (a) Write the assumptions of Winkler Bach formula. 6
 (b) An open ring having 'T' section as shown in figure 2 9 is subjected to a compressive load of 100 kN. Determine the stresses at A & B.



- 3 (a) Discuss significance of theories of failure. 6

OR

- (a) Differentiate between max. principal stress theory and max principal strain theory of failure. 6
- (b) A bolt is subjected to an axial pull of 25 kN and a transverse shear force of 15 kN. Determine the diameter of the bolt using maximum shear stress theory. The allowable shear stress in the bolt is 300 N/mm². 9

OR

- (b) Write short notes on (any **three**): 9
- (i) Fictitious load method for deflection analysis
 - (ii) Differential equations of equilibrium
 - (iii) Thermo elastic stress-strain relationship
 - (iv) Stress in a chain link
 - (v) Maxwell's reciprocal theorem.

SECTION - II

- 4 (a) Fill in the blanks : 10
- (i) The maximum circumferential stress in a disc with a pin hole at the centre is _____ the maximum circumferential stress in a solid disc.
 - (ii) The efficiency of welded joint is _____ than that of riveted joints.
 - (iii) The depth of weld in case of a butt weld is equal to _____.
 - (iv) The strouhal number is based on _____ and average flow velocity at minimum cross section between tube.
 - (v) The radial stress in hollow circular rotating disc is at _____.

- (vi) At the centre of the rotating solid disc the radial and circumferential stresses are _____.
- (vii) the circumferential stress in rotating solid circular cylinder is maximum at _____.
- (viii) In eccentric weld connection, weld has to offer resistance against _____ and _____.
- (ix) A thin flat ring is rotating at a speed of 'v' the circumferential stress induced is given by _____.

(b) Attempt following :

- (i) Hoop stress in rotating disc. 2
 - (ii) Mach Number 2
 - (iii) Reynold's no 2
 - (iv) Disadvantages of welded joints 4
- 5 (a) Write the advantages of the welded connect. 5

OR

- (a) Find the minimum lap required for the joint as shown in the figure 3 if 8 mm weld are used. Permissible shear stress in weld may be taken as 102.5 N/mm². 5

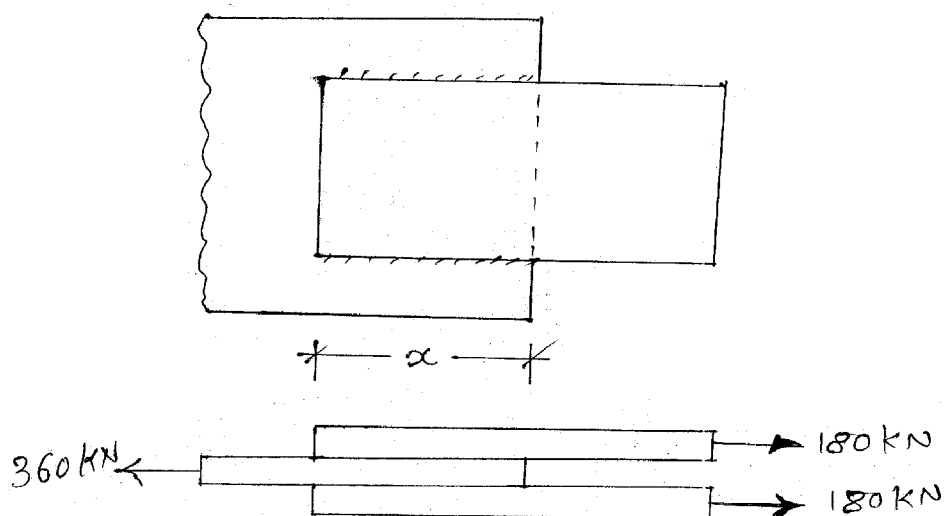

- (b) Find the maximum load per mm run on the weld arrangement as shown in figure 4.

10

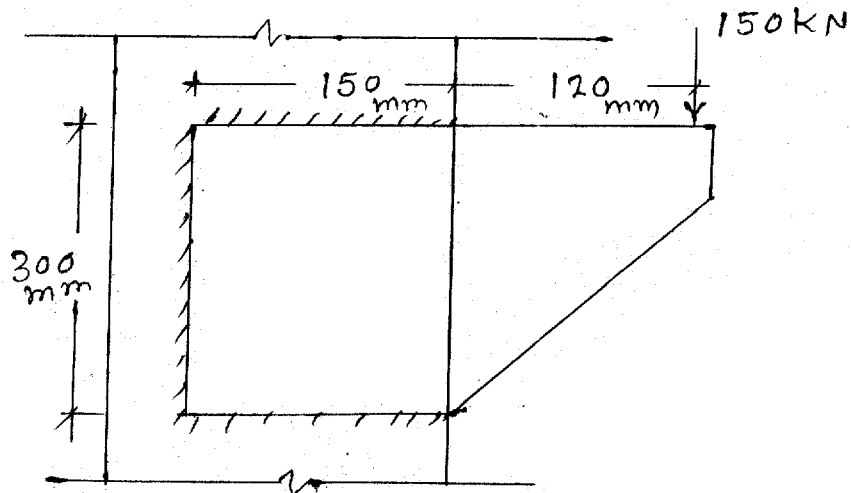

OR

- (b) For maximum shear stress in weld limited to 120 MPa. Determine the size of weld joint as shown in figure 5. Take $P = 200$ kN, $e = 100$ mm. Outside diameter 140 mm and inside diameter 120 mm.

10

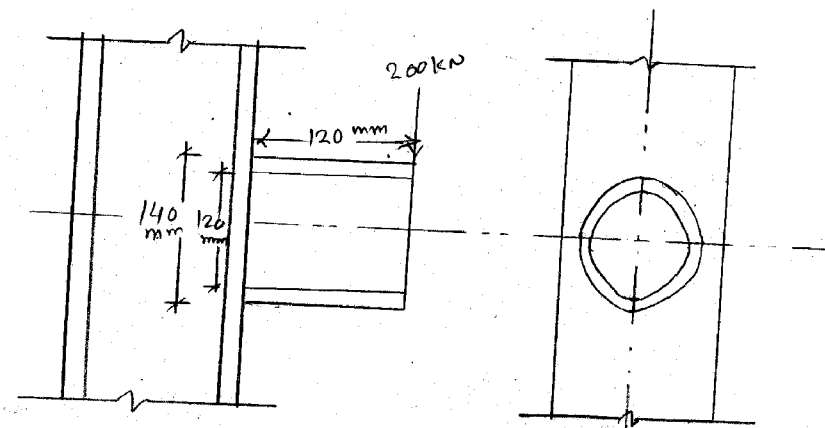

- 6 (a) Derive an equation for hoop stress in rotating ring. 5

OR

- (a) For a rotating disc of dia 800 mm having hollow inner part of dia 400 mm rotating at an rpm of 4200. Plot the variation of radial and circumferential stresses, if unit weight of material is 80 kN/m^3 and Poisson's ratio is 0.25. 5
- (b) For rotating disc of uniform thickness, when the maximum hoop stress reaches the permissible stress limit of 280 MPa, the maximum radial stress attains a value of 47.37 MPa. 10

The disc is having a hole of certain unknown diameter. Find the internal and external diameter of the disc, if speed of rotation is 3872.75 rpm. Take Poisson's ratio as 0.20 and mass density = 8000 kg/m^3 .